

**SERVICE INFORMATION**

**Number:** 291-1098

**Year:** 1989

**Month:** DECEMBER

**Market:** ALL

**Replacement of turbo unit**

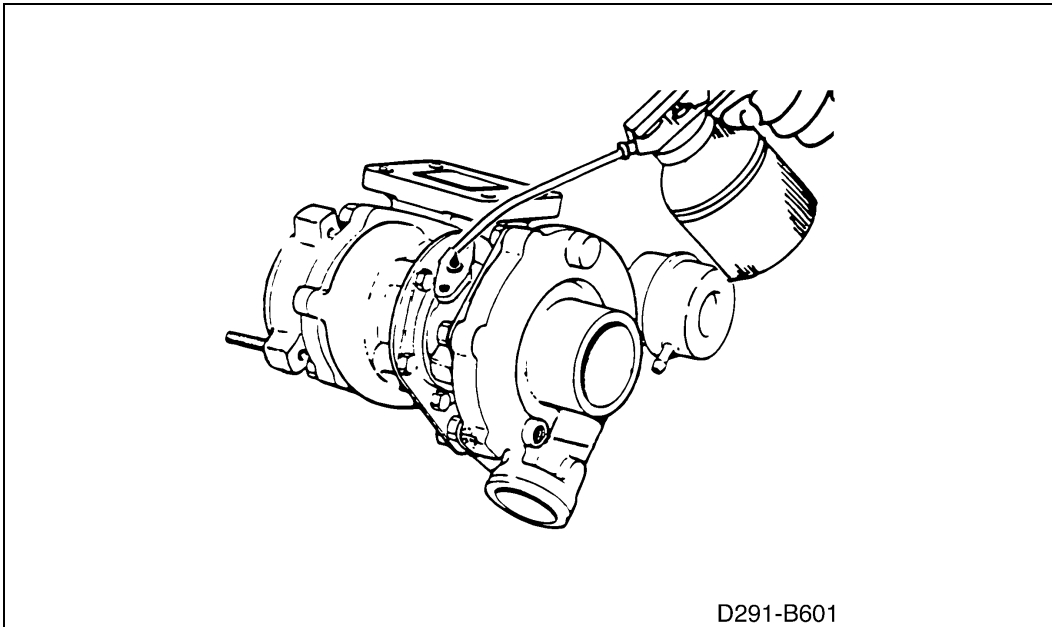

Replacement turbo units can be seriously damaged by inadequate initial lubrication, with the result that they have to be scrapped.

**Procedure**

This will ensure that an adequate film of oil will be present between the turbine shaft and bearing during the period it takes for the oil pressure to build up after the engine has been started for the first time following fitting of the replacement unit.

Before fitting a replacement unit, fill the lubricating oil passage with engine oil as shown.