

**MODIFICATION INSTRUCTION**

Bulletin Nbr: 291-2219  
Date:.....februari 2000  
Market: all

**Substandard turbo hose**

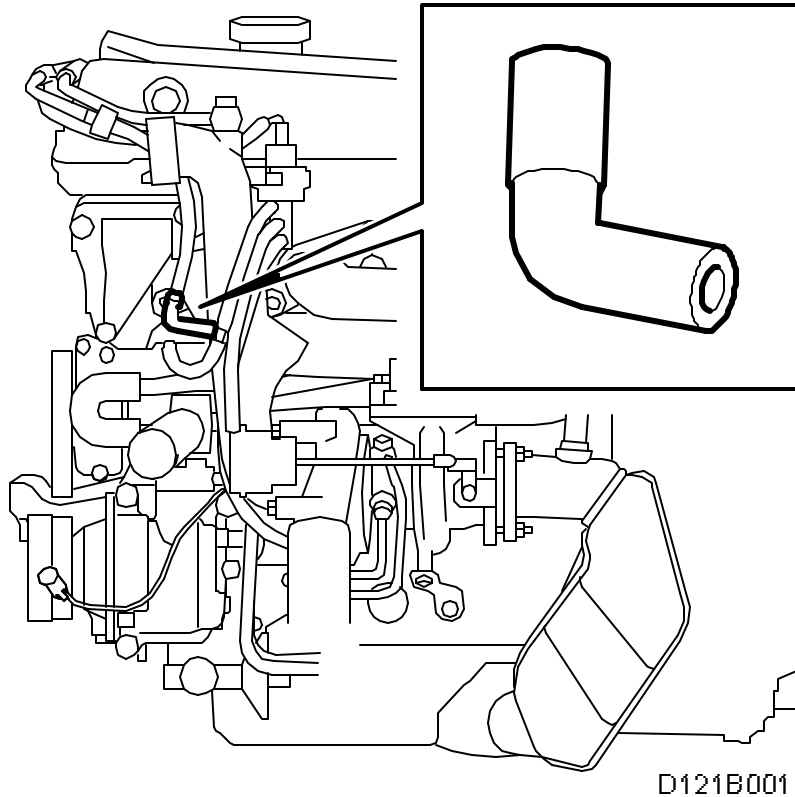

**Emission-related campaign 10720**

Cars in stock must be remedied before delivery.

A personal communication must be sent to the owners of cars already delivered requesting them to get in touch with the nearest Saab garage as soon as possible to have the fault rectified.

**Cars affected**

Saab 9-3, M00 with engine variants B205L, B205R and B235R, up to and including VIN Y2018486 3D/5D and Y7006098 CV.

**Background**

The quality of the material used for the elbow hose, fitted to the evacuation line by the turbo, is insufficient for the high surrounding temperature and therefore hardens. A new hose material has been introduced as of VIN Y2018486 and Y7006098 respectively.

**Symptoms**

Reduced drivability.

### Parts required

53 30 477 Elbow hose.

91 94 069 T-piece (if required)

---

### Important

The new angular hoses are still marked with part number 4752671 but they have a punch mark to the left of the part number.

---

### Procedure

1. Undo the lower hose clip on the elbow hose.

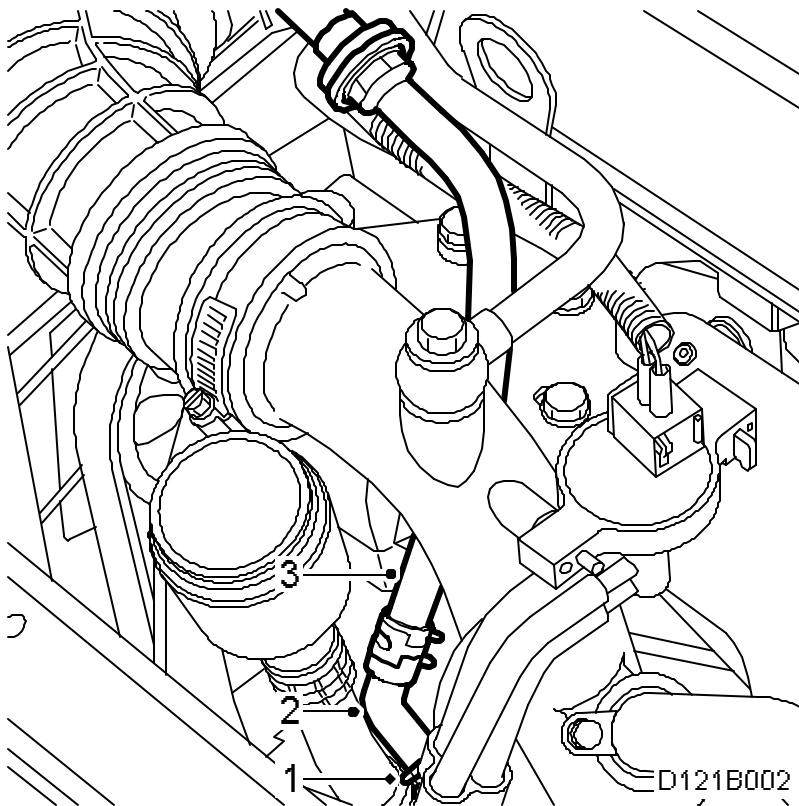

2. Remove the elbow hose from the APC valve T-piece. Be careful not to damage the T-piece. If necessary, replace the T-piece, (part no. 91 94 069).
3. Pull up the evacuation line.

- Undo and slide up the upper hose clip on the elbow hose. (The illustrations shows elbow hose 53 30 477 with the old part number and punch mark).

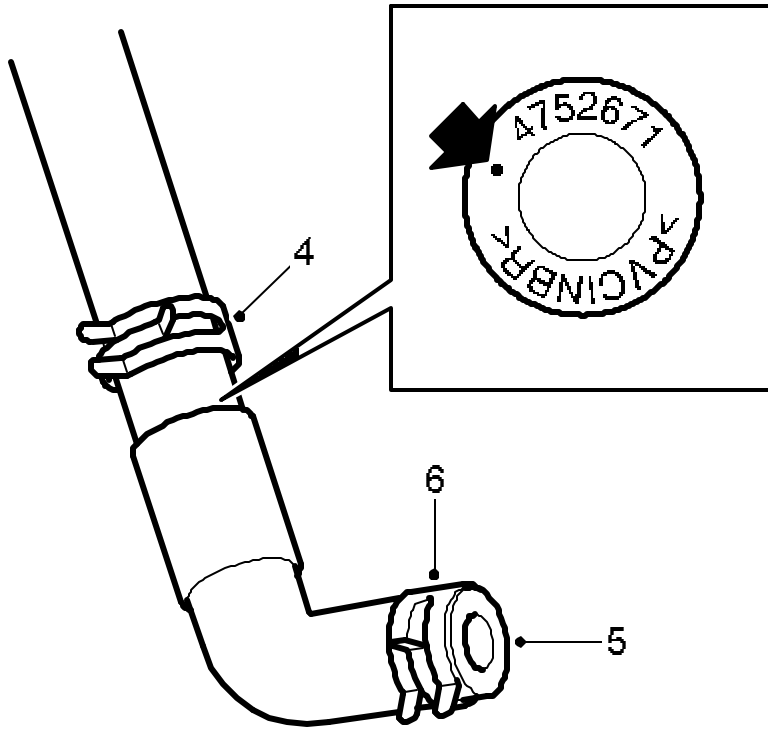

D121B003

- Note the orientation of the elbow hose. Remove the elbow hose.
- Transfer the lower hose clip to the new elbow hose. Position the hose clip 2-3 mm from the end of the hose.
- Fit the new elbow hose to the evacuation line. Make sure that the elbow hose is oriented as the old hose.
- Slide the upper hose clip down onto the elbow hose. Position the hose clip 2-3 mm from the end of the hose.
- Pull the evacuation line down between the turbo intake manifold and the hose to the A/C system's expansion tank.

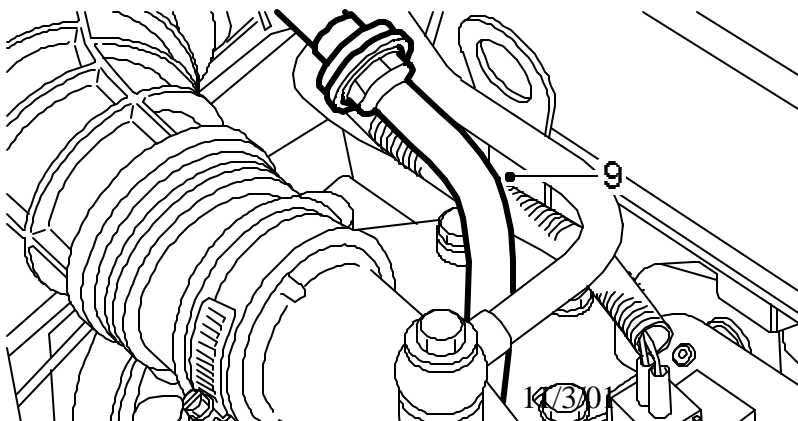

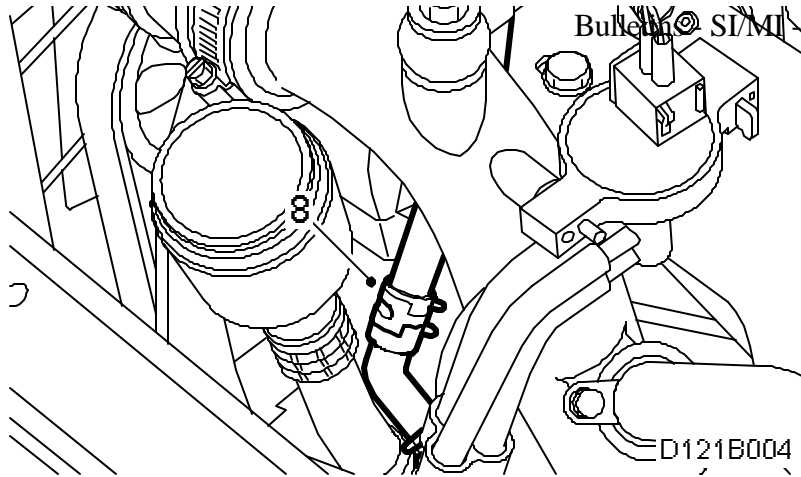

10. Fit the elbow hose to the T-piece.

**Marking the modification identity plate**

On completion of the necessary rectification, box A1 on the modification identity plate must be marked. If the work was carried out by the importer, mark the box with a "7". If done by a dealer, mark it with an "8".

**Warranty/Time information**

See separate information.