

SERVICE INFORMATION

Bulletin Nbr: 391-1965

Date:.....APRIL 1998

Market: US, CA

Handsfree installation and glass-mounted mobile telephone antenna

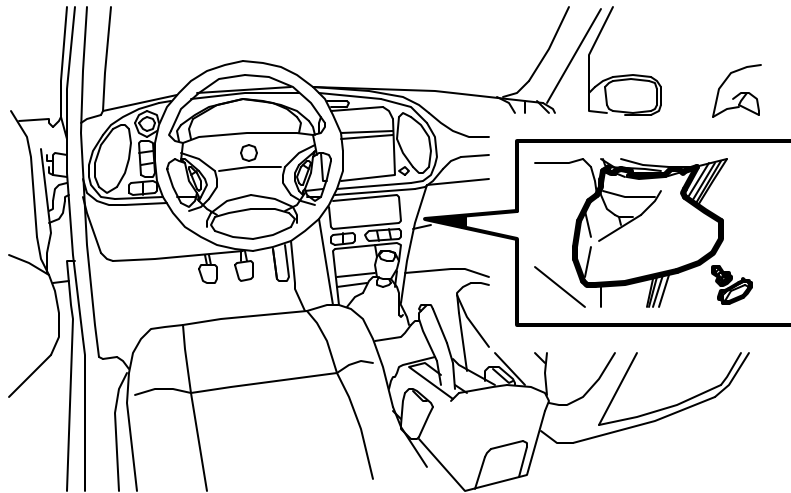

D391B615

Cars affected

Saab 9-3 M98-

Background

Saab 9-3 is pre-wired for installing a mobile telephone. There are two different levels of pre-wiring:

Telephone connection (Tel 0) and Handsfree connection (Tel 1). Tel 1 is not available for Saab 900 Convertibel

The telephone connection (Tel 0) is ready for installing a mobile telephone via a 10-pin connector in the dashboard, to which the telephone can be connected. There is no pre-wired coaxial cable for the mobile antenna.

Functions obtained with a pre-wired telephone connection are disconnection of the normal audio system sound during a telephone call (provide a Saab Audio System is used), power supply and battery recharging for the mobile telephone, and the TELEPHONE message displayed on SID during the telephone call.

The handsfree connection (Tel 1) is ready for installing a handsfree system for the mobile

telephone via a 10-pin connector in the dashboard. A pre-wired handsfree installation includes an integral microphone in the front roof console for improved acoustics, use of the existing loudspeaker system (provided that Saab Audio System is fitted) and pre-wired coaxial cable for the mobile antenna.

Functions obtained with a pre-wired handsfree connection are disconnection of the normal audio system sound during a telephone call, power supply and battery charging for the telephone. The volume of the telephone call can be adjusted with the volume control on the audio system and the TELEPHONE message is displayed on SID during the telephone call.

The glass-mounted antenna used by Saab is adapted to the GSM 900/1800 and NMT 900 systems.

It is important that the antenna is fitted according to the directions recommended by Saab in this SI and in the antenna installation instructions.

This SI contains detailed directions for connecting the following telephones and glass-mounted antennas.

- Nokia 2110 on page 4.
- Nokia 1610 on page 6.
- Motorola d 460 on page 8.
- Motorola Star Tac on page 10.
- Ericsson GH 600/700 range on page 12.
- Glass-mounted GSM 900/1800 antenna on page 14.

For other models of telephone, refer to the wiring diagrams for the telephone and the handsfree kit.

Parts required

For a more detailed list of parts refer to the respective telephone installation in this SI.

A general installation is described on the next page.

- A. Saab 9-3, Tel 1
- B. Adapter cable 400 108 130
- C. Handsfree kit (manufacturer's original kit)
 - v C.1. Holder

- √ C.2. Loudspeaker
- √ C.3. DHFA
- √ C.4. Wiring
- √ C.5. Telephone cable
- √ C.6. Microphone
- √ C.7. Fuses
- D. Parts to be purchased from external sources
 - √ D.1. Antenna cable adapter
 - √ D.2. Microphone jack plug
 - √ D.3. Loudspeaker jack plug
 - √ D.4. (Mute cable)
- E. Parts not used from the handsfree kit
 - √ E.1. Microphone
 - √ E.2. Loudspeaker

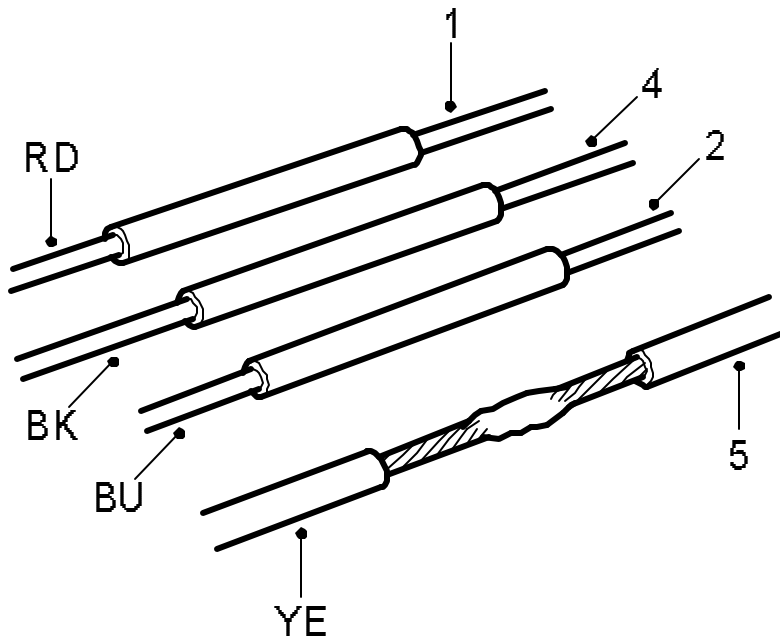

Procedure

Installation of NOKIA 2110

Parts required

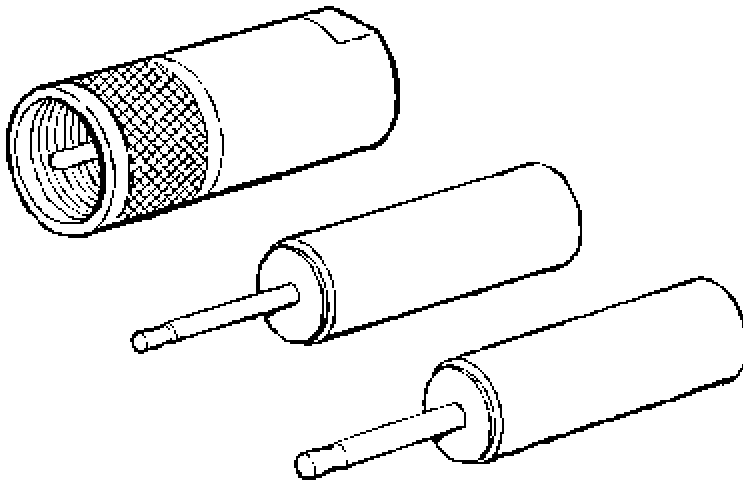

D391B603

- 400 109 179 Adapter cable
- 50 36 850 Installation instructions for the adapter cable (included in kit 400 109 179)
- Antenna cable adapter (purchased separately)
- NOKIA 2110 original handsfree kit (purchased separately)
- 3.5 mm jack plug (mono) for loudspeaker (purchased separately)
- 2.5 mm jack plug (mono) for microphone (purchased separately)
- Shrink tube Ø 3 mm, approx. 150 mm

- 50 36 348 Installation instructions for the 9-3 telephone console (included in kit 400 110 334/342)

Note

Mark the adapter cable with the relevant pin numbers before commencing work.

1. Follow installation instructions 50 36 850 up to and including step 6.
2. New step 7:

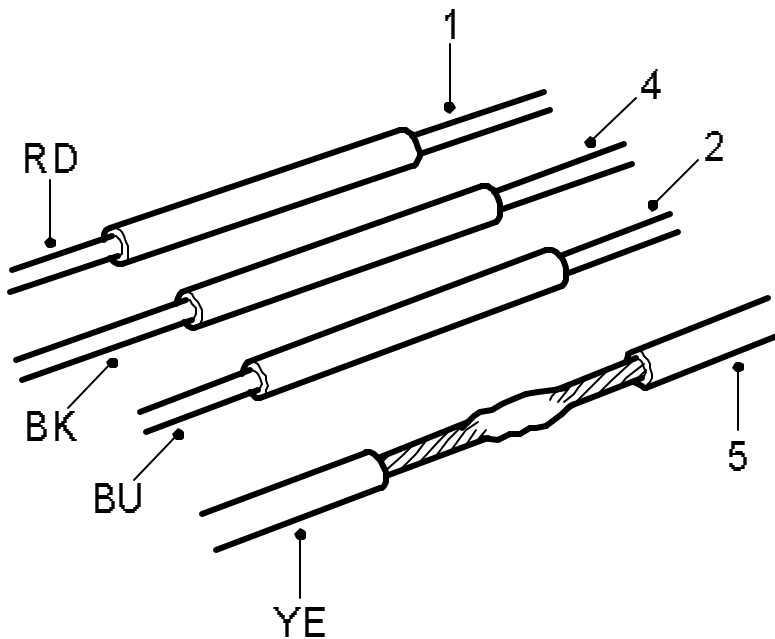

D391B604

- 2.a. Make sure a lead **is not** connected to the adapter cable connector, pos. 6.

If there is a lead connected, pull out the pin for the black lead in pos. 8 and replace it with the pin for the blue/white lead from pos. 6 in the adapter cable connector.

- 2.b. Place a piece of shrink-tubing over the red lead on the adapter cable and solder together the red lead from the telephone's handsfree kit with the red lead in pos. 1 on the adapter cable. Slide the shrink-tubing over the soldered joint and heat it.

- 2.c. Place a piece of shrink-tubing over the black lead on the adapter cable and solder together the black lead from the telephone's handsfree kit with the black lead in pos. 4 on the adapter cable. Slide the shrink-tubing over the soldered joint and heat it.
- 2.d. Place a piece of shrink-tubing over the blue/red lead on the adapter cable and solder together the blue lead from the telephone's handsfree kit with the blue/red lead in pos. 2 on the adapter cable. Slide the shrink-tubing over the soldered joint and heat it.
- 2.e. Place a piece of shrink-tubing over the yellow lead on the adapter cable and solder together the yellow lead from the telephone's handsfree kit with the yellow lead in pos. 5 on the adapter cable. Slide the shrink-tubing over the soldered joint and heat it.
- 2.f. Microphone:

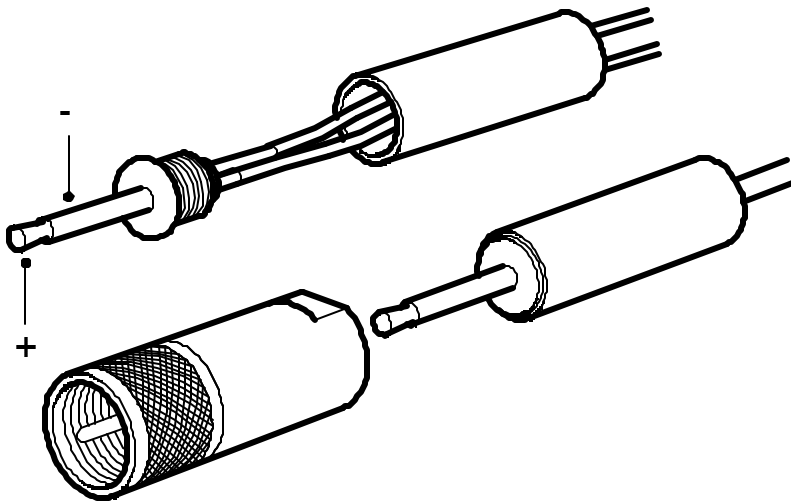

D391B616

Use an ohmmeter to determine which of the terminals is the (+) and (-) of the jack plug.

Solder the brown/grey lead in pos. 10 on the adapter cable to the (+) terminal on the jack plug.

Solder the green lead in pos. 3 on the adapter cable to the (-) terminal on the jack plug.

2.g. Loudspeaker:

Use an ohmmeter to determine which of the terminals is the (+) and (-) of the jack plug.

Solder the grey/white lead in pos. 7 on the adapter cable to the (+) terminal on the jack plug.

Solder the blue/white lead in pos. 8 on the adapter cable to the (-) terminal on the jack plug.

2.h. Connect the microphone and loudspeaker jack plugs to the telephone's handsfree module.

2.i. Connect the antenna cable with the adapter to the antenna cable on the telephone's handsfree kit.

2.j. Continue with installation instructions 50 36 850 steps 8-11.

3. Then fit the telephone console as described in installation instructions 50 36 348.

Installation of NOKIA 1610

Parts required

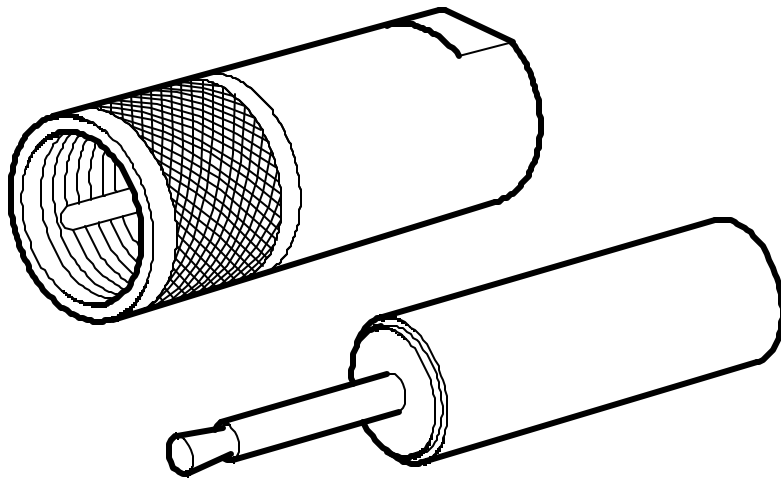

D391B619

- 400 109 179 Adapter cable
- 50 36 850 Installation instructions for the adapter cable (included in kit 400 109 179)
- Antenna cable adapter (purchased separately)
- NOKIA 1610 original handsfree kit (purchased separately)
- 2.5 mm jack plug (mono) for microphone (purchased separately)
- Shrink tube Ø 3 mm, approx. 70 mm
- 50 36 348 Installation instructions for the 9-3 telephone console (included in kit 400 110 334/342)

The car's loudspeaker system is not used.

Note

Mark the adapter cable with the relevant pin numbers before commencing work.

1. Follow installation instructions 50 36 850 up to and including step 6.
2. New step 7:

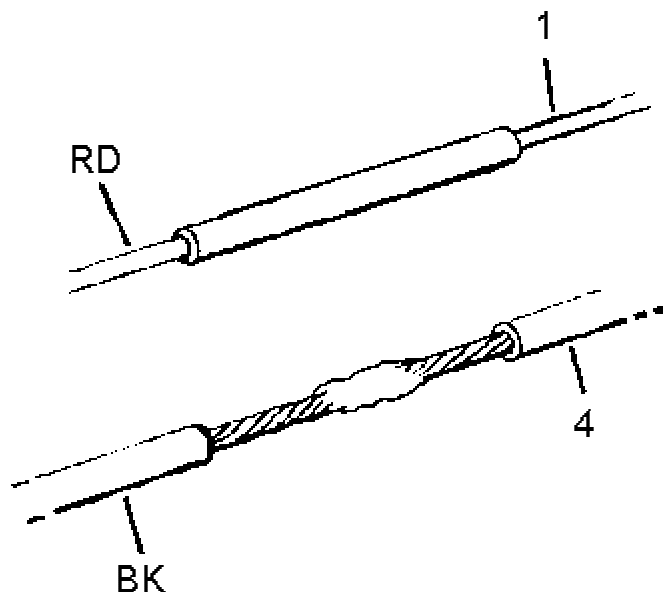

2.a. Make sure a lead **is not** connected to the adapter cable connector, pos. 6.

If there is a lead connected, pull out the pin for the black lead in pos. 8 and replace it with the pin for the blue/white lead from pos. 6 in the adapter cable connector.

2.b. Place a piece of shrink-tubing over the red lead on the adapter cable and solder together the red lead from the telephone's handsfree kit with the red lead in pos. 1 on the adapter cable. Slide the shrink-tubing over the soldered joint and heat it.

2.c. Place a piece of shrink-tubing over the black lead on the adapter cable and solder together the black lead from the telephone's handsfree kit with the black lead in pos. 4 on the adapter cable. Slide the shrink-tubing over the soldered joint and heat it.

2.d. Microphone:

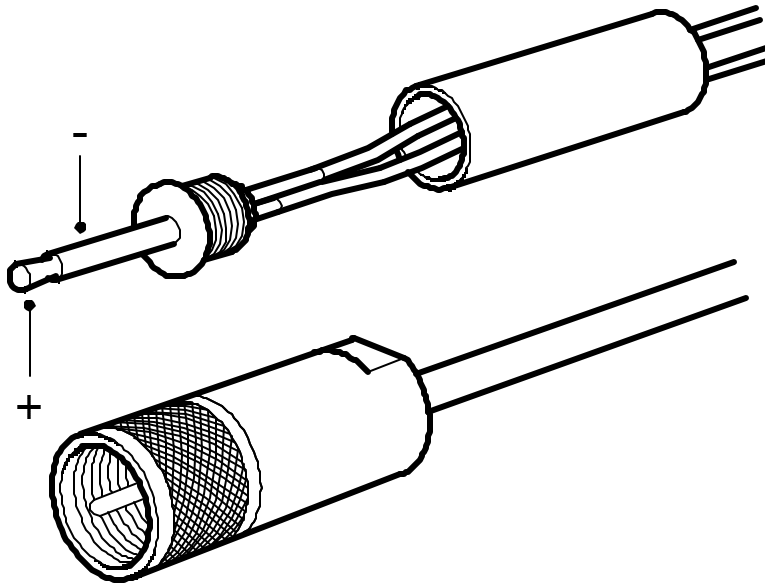

D391B618

Use an ohmmeter to determine which of the terminals is the (+) and (-) of the jack plug.

Solder the brown/grey lead in pos. 10 on the adapter cable to the (+) terminal on the jack plug.

Solder the green lead in pos. 3 on the adapter cable to the (-) terminal on the

jack plug.

2.e. Connect the microphone jack plug to the telephone's handsfree module.

2.f. Connect the antenna cable with the adapter to the antenna cable on the telephone's handsfree kit.

2.g. Continue with installation instructions 50 36 850 steps 8-11.

3. Then fit the telephone console as described in installation instructions 50 36 348.

Installation of Motorola d 460

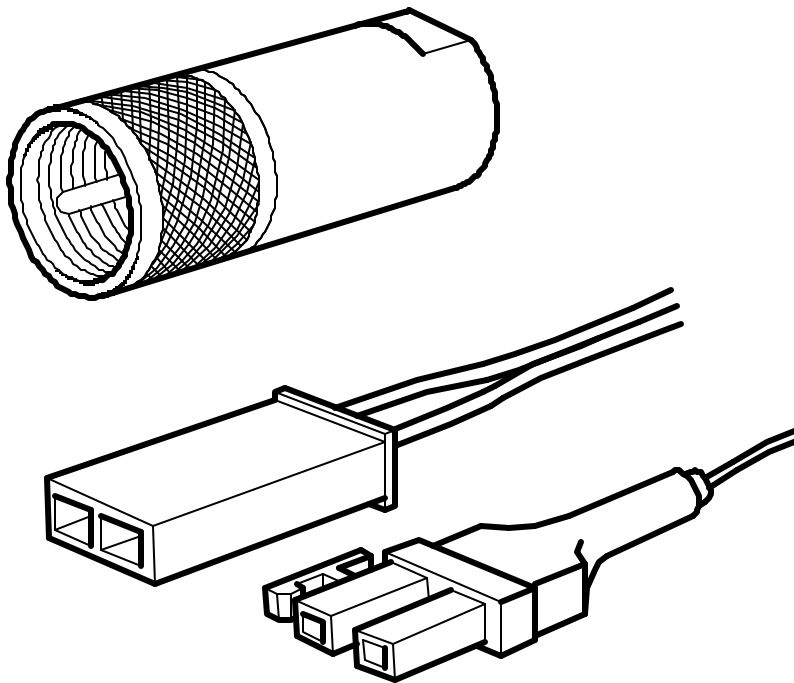

D391B609

Parts required

- 400 109 179 Adapter cable
- 50 36 850 Installation instructions for the adapter cable (included in kit 400 109 179)
- Antenna cable adapter (purchased separately)
- Motorola d 460 original handsfree kit (purchased separately)
- Shrink tube Ø 3 mm, approx. 220 mm

- 50 36 348 Installation instructions for the 9-3 telephone console (included in kit 400 110 334/342)

Use the connectors included with the handsfree kit to install the microphone and loudspeaker.

Note

Mark the adapter cable with the relevant pin numbers before commencing work.

1. Follow installation instructions 50 36 850 up to and including step 6.
2. New step 7:

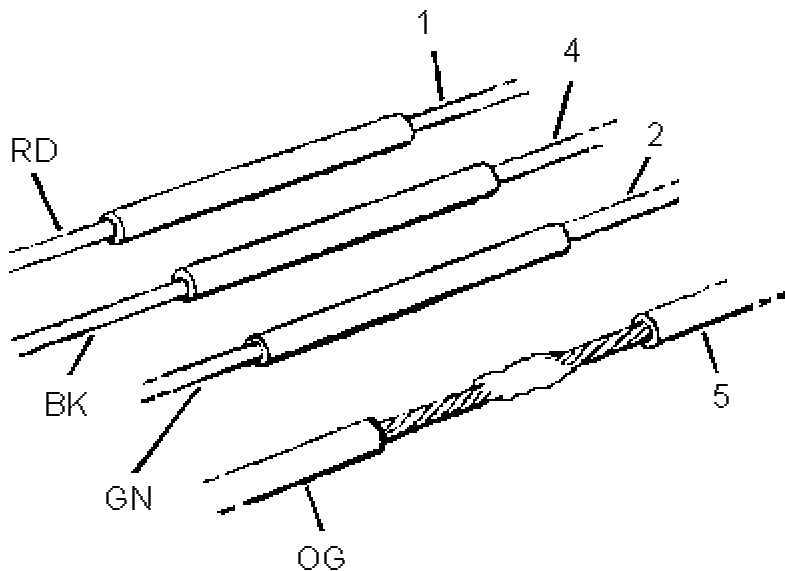

D391B610

- 2.a. Make sure a lead **is not** connected to the adapter cable connector, pos. 6.

If there is a lead connected, pull out the pin for the black lead in pos. 8 and replace it with the pin for the blue/white lead from pos. 6 in the adapter cable connector.

- 2.b. Place a piece of shrink-tubing over the red lead on the adapter cable and solder together the red lead from the telephone's handsfree kit with the red lead in pos. 1 on the adapter cable. Slide the shrink-tubing over the soldered joint and heat it.

- 2.c. Place a piece of shrink-tubing over the black lead on the adapter cable and solder together the black lead from the telephone's handsfree kit with the black lead in pos. 4 on the adapter cable. Slide the shrink-tubing over the soldered joint and heat it.
- 2.d. Place a piece of shrink-tubing over the blue/red lead on the adapter cable and solder together the green lead from the telephone's handsfree kit with the blue/red lead in pos. 2 on the adapter cable. Slide the shrink-tubing over the soldered joint and heat it.
- 2.e. Place a piece of shrink-tubing over the yellow lead on the adapter cable and solder together the orange lead from the telephone's handsfree kit with the yellow lead in pos. 5 on the adapter cable. Slide the shrink-tubing over the soldered joint and heat it.
- 2.f. Microphone:

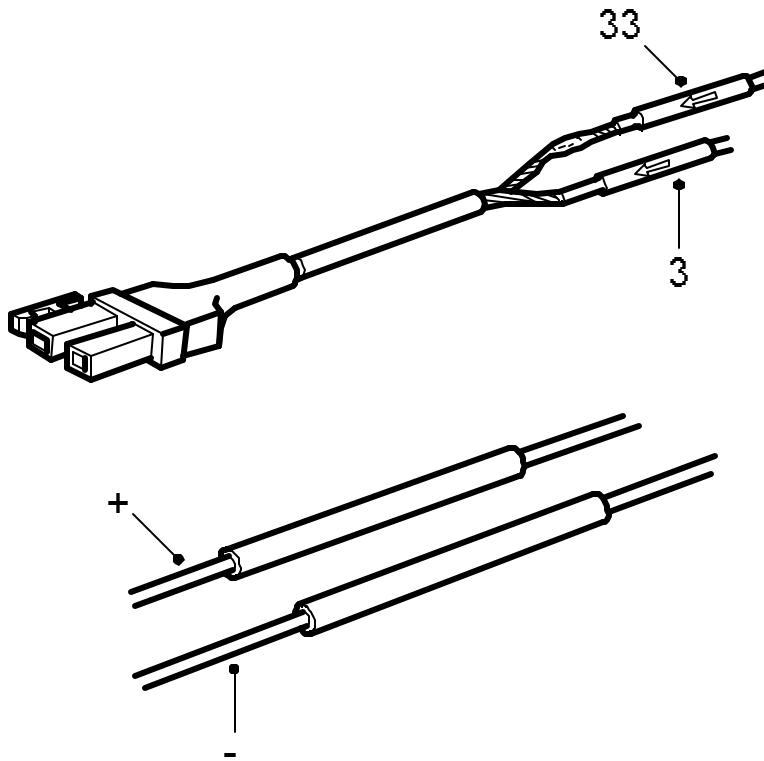

D391B612

Important

Be careful with the heat from the soldering iron when soldering the microphone cable. The plastic melts easily.

Cut off the connector for the microphone in the handsfree kit. Place a piece of shrink-tubing over the green lead in pos. 3 on the adapter cable and solder the screen of the microphone cable to the green lead in pos. 3 on the adapter cable. Slide the shrink-tubing over the soldered joint and heat it carefully.

Place a piece of shrink-tubing over the brown/grey lead in pos. 10 on the adapter cable and solder the conductor in the microphone cable to the brown/grey lead in pos. 10 on the adapter cable. Slide the shrink-tubing over the soldered joint and heat it carefully.

2.g. Loudspeaker:

Note

Before cutting off the connector for the loudspeaker in the handsfree kit: Open the loudspeaker and mark up the leads on the connector with (+) and (-).

Solder the grey/white lead in pos. 7 on the adapter cable to the (+) terminal on the connector.

Solder the blue/white lead in pos. 8 on the adapter cable to the (-) terminal on the connector.

2.h. Connect the microphone and loudspeaker connectors to the telephone's handsfree module.

2.i. Connect the antenna cable with the adapter to the antenna cable on the telephone's handsfree kit.

2.j. Continue with installation instructions 50 36 850 steps 8-11.

3. Then fit the telephone console as described in installation instructions 50 36 348.

Installation of Motorola Star Tac

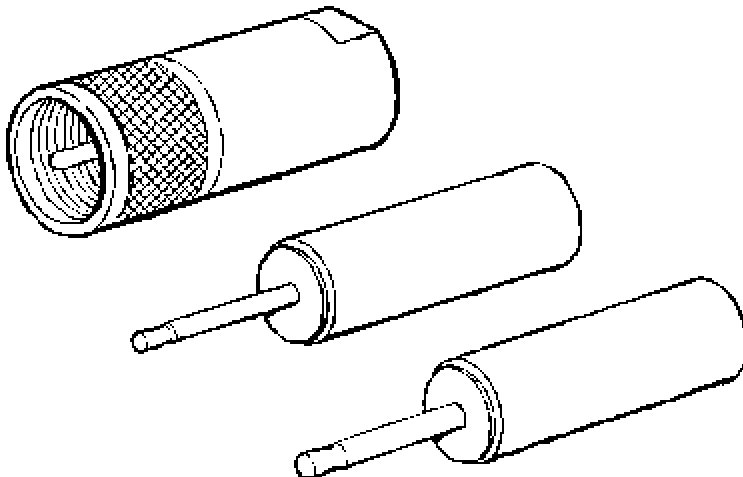

Parts required

- 400 109 179 Adapter cable
- 50 36 850 Installation instructions for the adapter cable (included in kit 400 109 179)
- Antenna cable adapter (purchased separately)
- Motorola Star Tac original handsfree kit (purchased separately)
- 3.5 mm jack plug (mono) for loudspeaker (purchased separately)
- 2.5 mm jack plug (mono) for microphone (purchased separately)
- Shrink tube Ø 3 mm, approx. 150 mm
- 50 36 348 Installation instructions for the 9-3 telephone console (included in kit 400 110 334/342)

Note

Mark the adapter cable with the relevant pin numbers before commencing work.

1. Follow installation instructions 50 36 850 up to and including step 6.
2. New step 7:

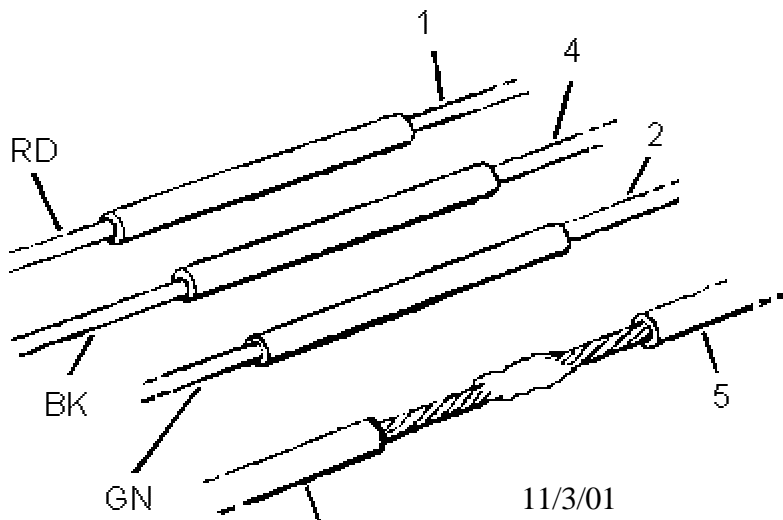

D391B610

2.a. Make sure a lead **is not** connected to the adapter cable connector, pos. 6.

If there is a lead connected, pull out the pin for the black lead in pos. 8 and replace it with the pin for the blue/white lead from pos. 6 in the adapter cable connector.

2.b. Place a piece of shrink-tubing over the red lead on the adapter cable and solder together the red lead from the telephone's handsfree kit with the red lead in pos. 1 on the adapter cable. Slide the shrink-tubing over the soldered joint and heat it.

2.c. Place a piece of shrink-tubing over the black lead on the adapter cable and solder together the black lead from the telephone's handsfree kit with the black lead in pos. 4 on the adapter cable. Slide the shrink-tubing over the soldered joint and heat it.

2.d. Place a piece of shrink-tubing over the blue/red lead on the adapter cable and solder together the green lead from the telephone's handsfree kit with the blue/red lead in pos. 2 on the adapter cable. Slide the shrink-tubing over the soldered joint and heat it.

2.e. Place a piece of shrink-tubing over the yellow lead on the adapter cable and solder together the orange lead from the telephone's handsfree kit with the yellow lead in pos. 5 on the adapter cable. Slide the shrink-tubing over the soldered joint and heat it.

2.f. Microphone:

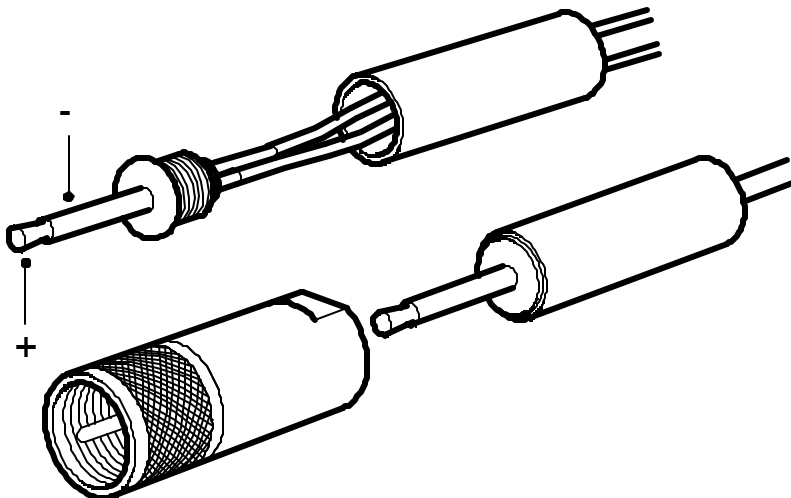

D391B616

Use an ohmmeter to determine which of the terminals is the (+) and (-) of the jack plug.

Solder the brown/grey lead in pos. 10 on the adapter cable to the (+) terminal on the jack plug.

Solder the green lead in pos. 3 on the adapter cable to the (-) terminal on the jack plug.

2.g. Loudspeaker:

Use an ohmmeter to determine which of the terminals is the (+) and (-) of the jack plug.

Solder the grey/white lead in pos. 7 on the adapter cable to the (+) terminal on the jack plug.

Solder the blue/white lead in pos. 8 on the adapter cable to the (-) terminal on the jack plug.

2.h. Connect the microphone and loudspeaker jack plugs to the telephone's handsfree module.

2.i. Connect the antenna cable with the adapter to the antenna cable on the telephone's handsfree kit.

2.j. Continue with installation instructions 50 36 850 steps 8-11.

3. Then fit the telephone console as described in installation instructions 50 36 348.

Installation of Ericsson GH 600/700 range

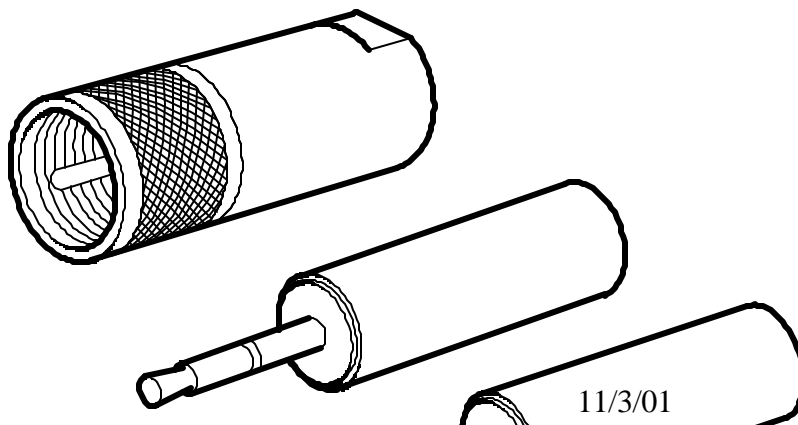



D391B611

Parts required

- 400 109 179 Adapter cable
- 50 36 850 Installation instructions for the adapter cable (included in kit 400 109 179)
- Antenna cable adapter (purchased separately)
- Ericsson GH 600/700 range original handsfree kit (purchased separately)
- 3.5 mm jack plug (mono) for loudspeaker (purchased separately)
- 3.5 jack plug (stereo) for the microphone (purchased separately)
- Mute cable KRY 11093-02 (Ericsson part no., purchased separately)
- Antenna cable adapter (purchased separately)
- Shrink tube Ø 3 mm, approx. 90 mm
- 50 36 348 Installation instructions for the 9-3 telephone console (included in kit 400 110 334/342)

Note

Mark the adapter cable with the relevant pin numbers before commencing work.

1. Follow installation instructions 50 36 850 up to and including step 6.

2. New step 7:

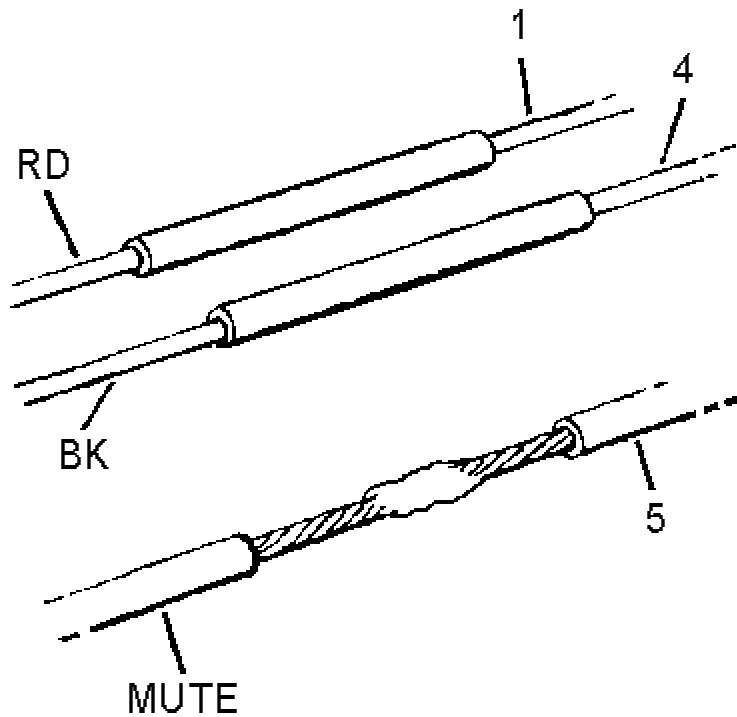

D391B613

2.a. Make sure a lead **is not** connected to the adapter cable connector, pos. 6.

If there is a lead connected, pull out the pin for the black lead in pos. 8 and replace it with the pin for the blue/white lead from pos. 6 in the adapter cable connector.

2.b. Place a piece of shrink-tubing over the red lead on the adapter cable and solder together the red lead from the telephone's handsfree kit with the red lead in pos. 1 on the adapter cable. Slide the shrink-tubing over the soldered joint and heat it.

2.c. Place a piece of shrink-tubing over the black lead on the adapter cable and solder together the black lead from the telephone's handsfree kit with the black lead in pos. 4 on the adapter cable. Slide the shrink-tubing over the soldered joint and heat it.

2.d. Place a piece of shrink-tubing over the yellow lead on the adapter cable and solder the Mute cable to the yellow lead in pos. 5 on the adapter cable. Slide the shrink-tubing over the soldered joint and heat it.

2.e. Microphone:

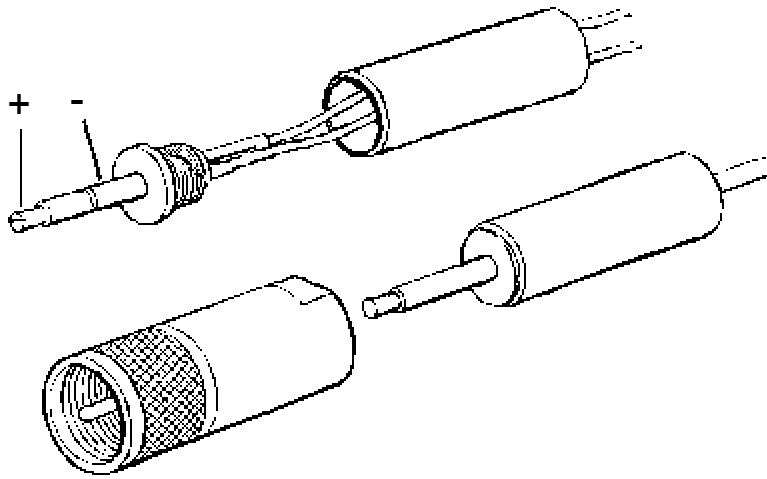

D391B605

Use an ohmmeter to determine which of the terminals is the (+) and (-) of the jack plug.

Solder the brown/grey lead in pos. 10 on the adapter cable to the (+) terminal on the jack plug.

Solder the green lead in pos. 3 on the adapter cable to the (-) terminal on the jack plug.

2.f. Loudspeaker:

Use an ohmmeter to determine which of the terminals is the (+) and (-) of the jack plug.

Solder the grey/white lead in pos. 7 on the adapter cable to the (+) terminal on the jack plug.

Solder the blue/white lead in pos. 8 on the adapter cable to the (-) terminal on the jack plug.

2.g. Connect the microphone and loudspeaker jack plugs to the telephone's handsfree module.

2.h. Connect the antenna cable with the adapter to the antenna cable on the telephone's handsfree kit.

- 2.i. Continue with installation instructions 50 36 850 steps 8-11.
3. Then fit the telephone console as described in installation instructions 50 36 348.

Glass-mounted antenna Saab 9-3, 3D and 5D

Development of a glass-mounted antenna for the Saab 9-3, 3D and 5D is in progress and will be available for sale from stock during week 818.

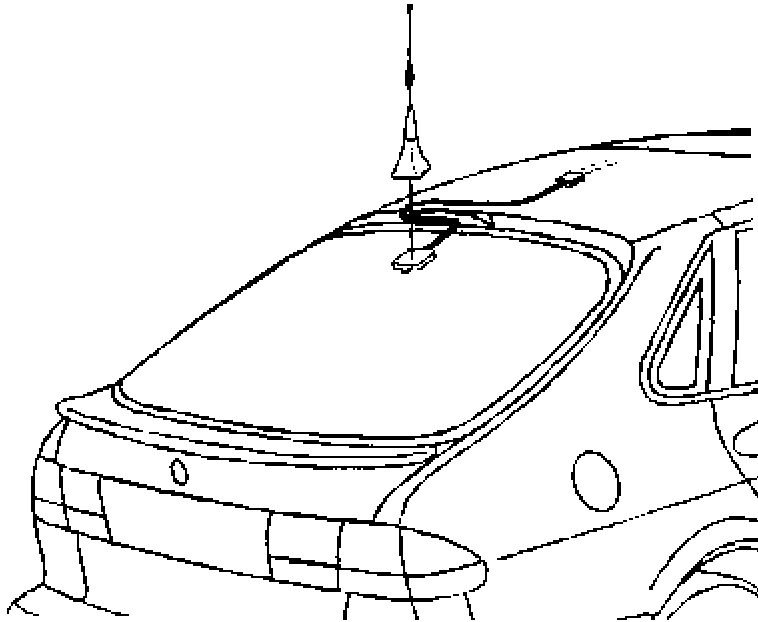

D391B614

The kit will have the following part and installation instructions numbers:

400 111 647 Telephone antenna, glass-mounted

50 41 447 Installation instructions

There is no alternative location for the glass-mounted antenna. The location described in the installation instructions is the optimal.

The adhesive used for glass-mounting has a service life of 3 years.

Glass-mounted antenna for Saab 9-3, convertible

There is no alternative location for the glass-mounted antenna on convertible models. The location on the passenger side of the windscreen described in installation instructions 48 72 776 included with kit 400 109 187 is the optimal (available for sale from stock during week 817).

The adhesive used for glass-mounting has a service life of 3 years.