

**SERVICE INFORMATION**

**Number:** 800-9004

**Year:** 1993

**Month:** OCTOBER

**Market:** US

**Lifting and Jacking Points**

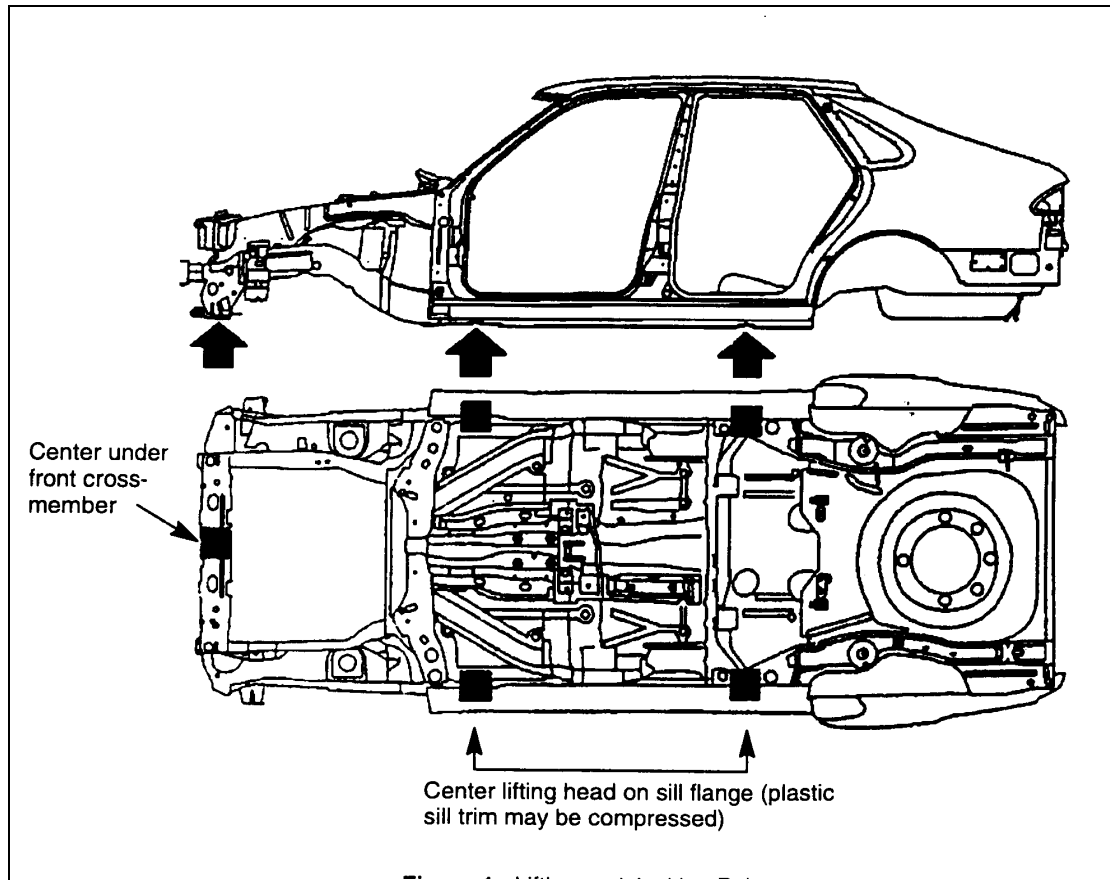

Take care when putting a new style 900 onto a lift or when using a jack to elevate the car. Please see the figure below for the locations for appropriate lifting and jacking points.

If you use incorrect lifting or jacking points, the vehicle could shift or fall from its elevated position, causing serious damage to the vehicle or personal injury to occur.

**NOTE**

Do not jack up the rear end of the car under the spare tire well or the rear axle as serious vehicle damage, such as a bent rear axle or deformed floor panel, can occur.