

**SERVICE INFORMATION**

Bulletin Nbr: 841-1577 ed. 3

Date:.....Januari 2000

Market: all

**Noise from the upper part of the windscreen**

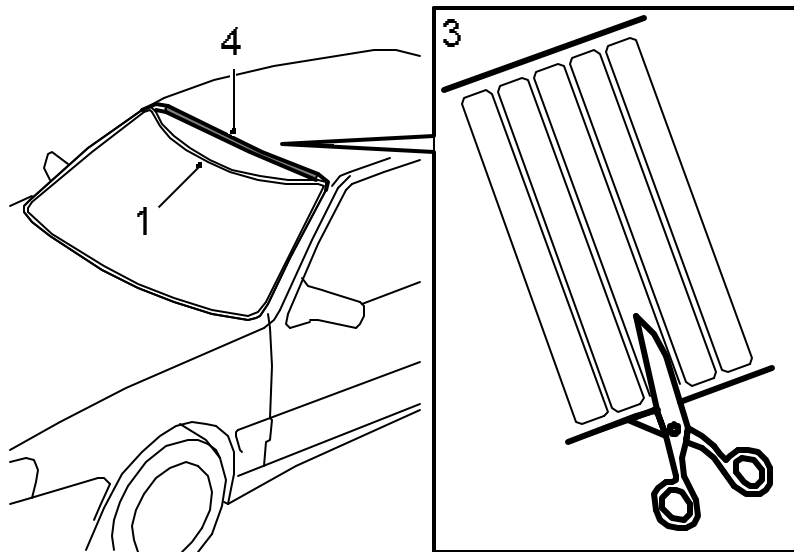

D843B625

**Cars affected**

Saab 9-3, 900 and 9000.

**Background**

On certain Saab 9-3, 900 and 9000 model cars a whistling noise can come from the top centre of the windscreen. The noise is especially apparent in hot weather and at high speeds.

**Parts required**

- 74 97 357 double-sided adhesive tape, sheet of 10 pcs., 5 pcs. per car
- (45) 30 15 815 Teroson cleaner FL, 1 litre pack

**Procedure**

In the case of customer complaint, the noise can be eliminated by fastening double-sided tape between the upper part of the windscreen trim and the roof panel.

If doing this when changing the windscreen, the tape should not be divided, see point 3, but used as it is on the card.

1. Lift the trim from the upper part of the windscreen.
2. Clean the edge of the roof panel and the trim on its contact surface against the panel with Teroson cleaner FL or similar.
3. Divide the tape while it is still on the sheet, see illustration.
4. Centre the first piece of tape in the middle. Continue to apply two pieces of tape on each side and close to the middle one.
5. Refit the trim.

#### **Warranty/Time information**

Failed Object: 841 41

Fault/Reason code: 40

Location code: 00

Repair/Action code: 05

Time: 0.2 hrs.