

SERVICE INFORMATION

Bulletin Nbr: 843-1587

Date:.....FEBRUARI 1995

Market: ALL

Adapting door mirror for tall drivers

Cars concerned

All Saab 900 M1994-

Background

In some cases it has been found that the door mirror on the driver's side needs to be angled outwards by a greater amount in order to give tall drivers a more convenient rearward vision. In the event of customer complaints, the angle can be increased on LHD cars by adding washers to two of the mirror mechanism's three mounting points. On RHD cars a single washer should be added to all three mounting points.

1

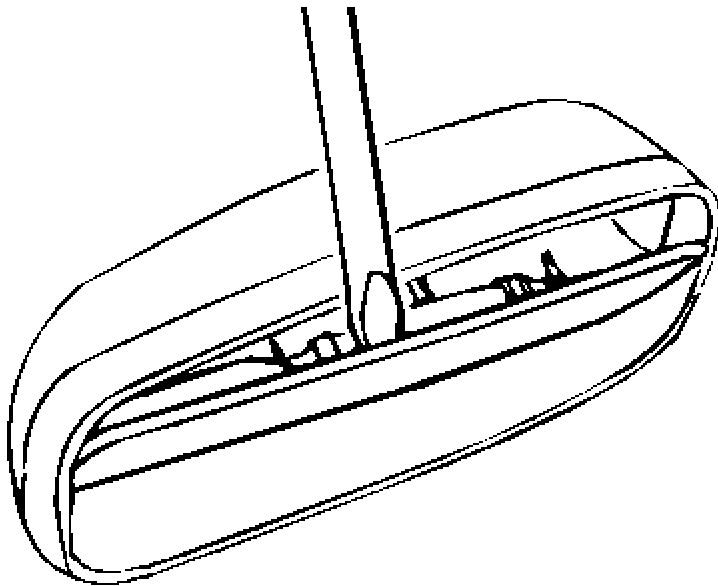

D843-B604

Materials

- (10) 84 28 997 washer
- 6 pcs. for LHD cars
- 3 pcs for RHD cars

Procedure

1. Remove the mirror glass using a large screwdriver.

2. Remove the screws securing the electric motor.

3. LHD cars:

Place 3 washers under two of the screws as shown in illustration A.

RHD cars:

Place 1 washer under each screw as shown in illustration B.

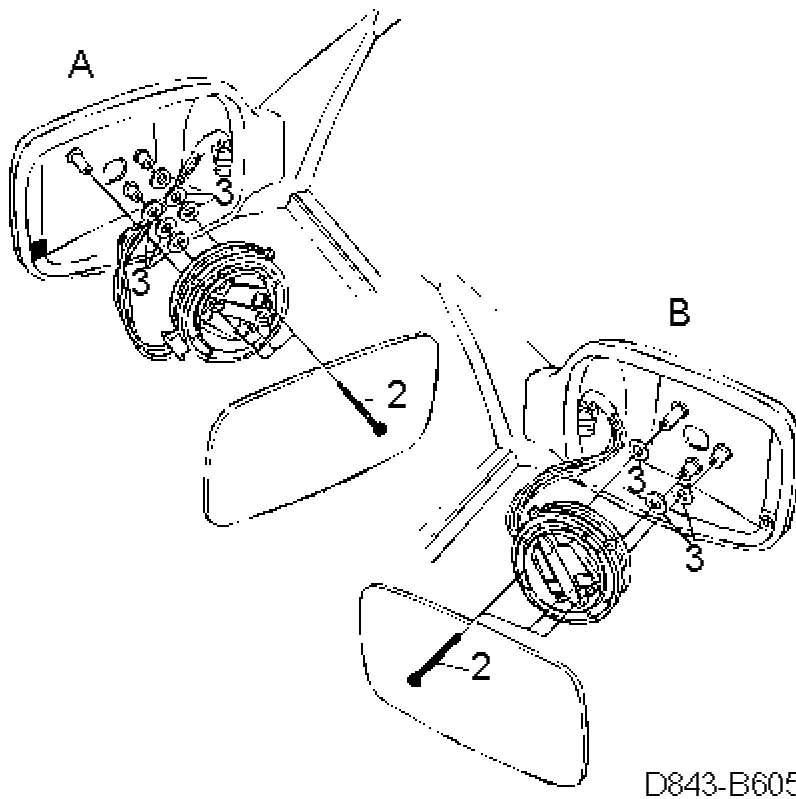

4. LHD cars:

Tighten the electric motor by first tightening the two screws with the washers. Do not overtighten. Then, tighten the last screw.

RHD cars:

Tighten the screws.

Tightening torque: 1.5 Nm (1.1 lbf ft)

5. Fit the mirror glass in place.
6. Check the operation of the mirror.

Warranty/Time information

Failed Object: 84370

Fault/Reason code: 79

Location code: 09

Repair/Action code: 05 Time: 0.1

Warranty information

Normal warranty regulations apply.