

TECHNICAL NEWS

Bulletin Nbr: 99-02-855a

Date:.....February 1999

Market: all

Locking mechanism, tailgate

Cars concerned

Saab 9-3 M98 - M99 up to and including VIN X2053929.

Background

The tailgate on certain cars has occasionally been difficult to open due to a few defective clips. If a clip falls out when the tailgate is locked, it will remain locked. If the clip falls out when the tailgate is open, it can not be locked again.

Parts required

48 59 336 Clip (blue)

Procedure

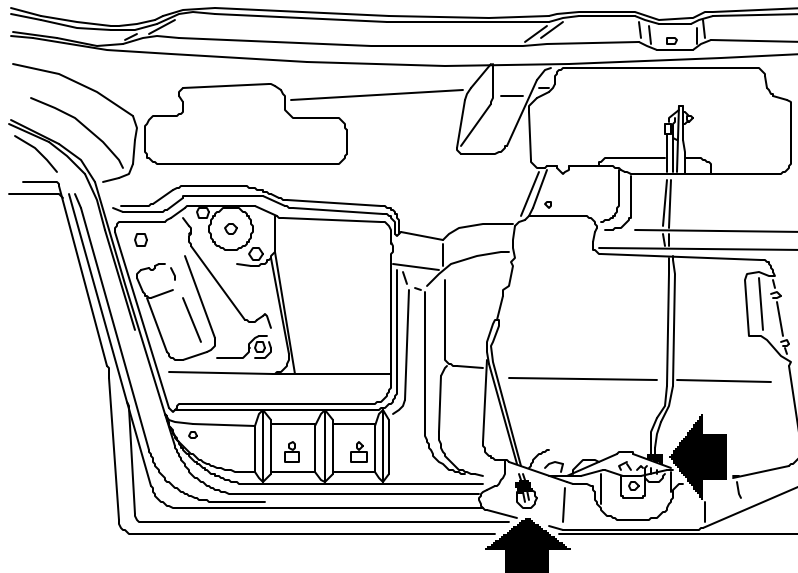

D855B603

Replace the black clip with the blue one. Remove the interior handle from the tailgate trim, remove four black clips, bend out the trim carefully, grasp the lock arm and press it down. This will unlock the tailgate. Go to the back of the car and open the tailgate, remove the trim and replace the clip. See illustration. Fit the tailgate trim and the interior handle.

If the clip securing the link arm to the lock cylinder is broken, it may be necessary to remove

the locking mechanism in order to replace the clip.